



Enriching Lives

## HYDROSTREAM THRU-BORE LOWEST LIFE-CYCLE COST (LLC) SERIES

TYPE - Horizontal Split Case Pump



**SINGLE STAGE PUMP**

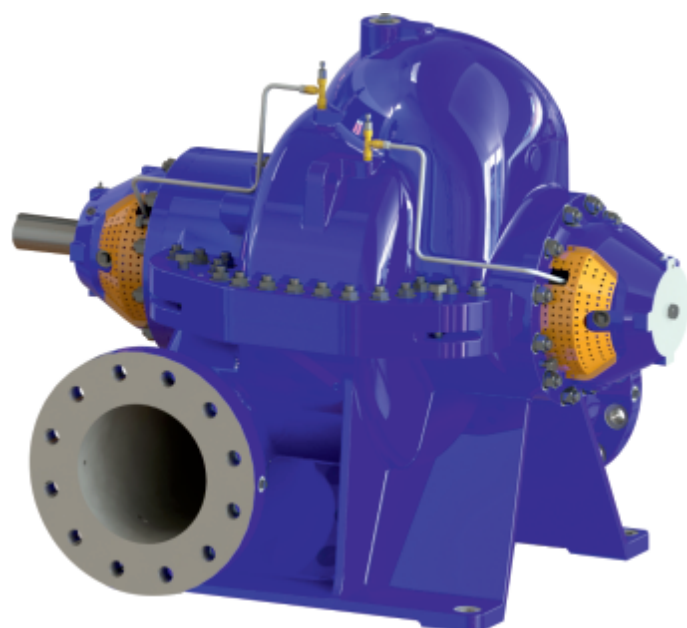

**TWO STAGE PUMP**

**KIRLOSKAR BROTHERS LIMITED**

Established 1888

A Kirloskar Group Company

## CUT SECTIONAL VIEW :

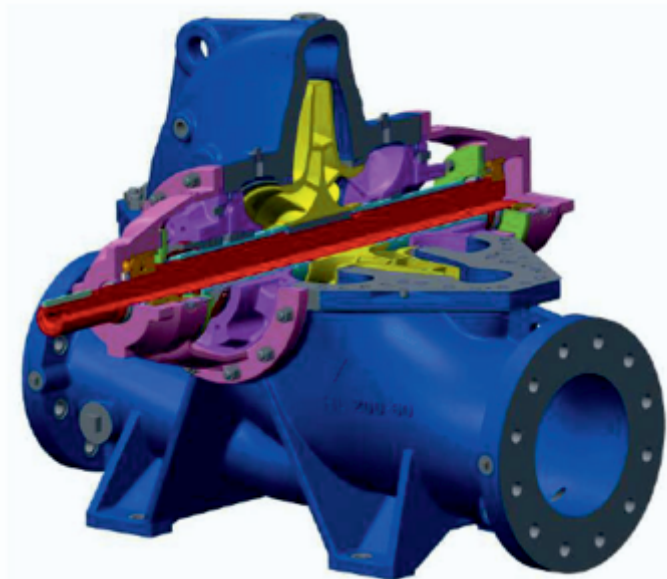

**SINGLE STAGE PUMP**

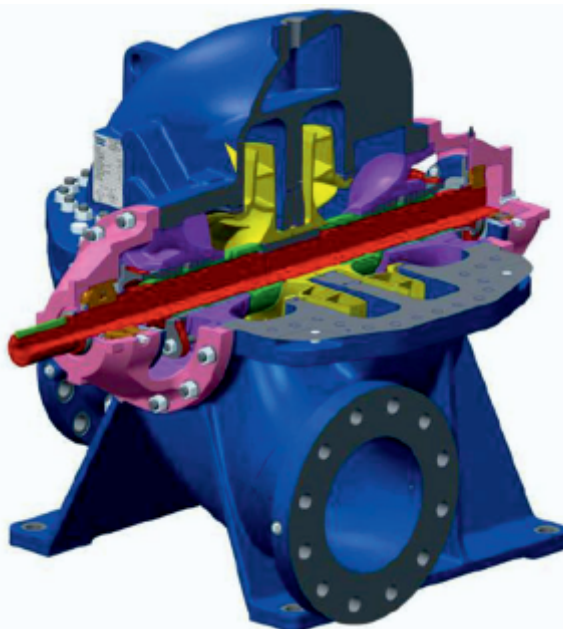

**TWO STAGE PUMP**

## MATERIAL OF CONSTRUCTION :

### STANDARD SCOPE :

- **UPPER and LOWER CASING** : CI FG 260+CORROCOAT+FLUEGLIDE-E-
- **IMPELLER** : ST ST ASTMA 351/351M-CF8M+ELECTROPOLISHING
- **SHAFT** : SS BSEN 10088-3 X17CrNi16-2(1.4057)QT800  
(OLD BS970 P1 431S29 H)

## CONSTRUCTIONAL FEATURES

KBL. Hydrostream Thru-bore LLC Series Horizontal Split Case Pumps are a range of centrifugal pumps horizontal axially split casing, single stage, double suction or single suction, single volute or double volute type pumps. These pumps are usually supplied as pump sets with electric motors but can be supplied separately for customers to fit to drivers of their own preference.

Rotating assembly accessible for inspection or maintenance by removing upper half casing without disturbing suction and delivery piping and motor.

- High hydraulic and overall efficiency
- Good suction performance
- Low NPSH requirement.
- Stable characteristics
- Minimum maintenance required
- High reliability

### **Pump Casing :**

The casing shall be of axially-split design with suction and discharge flanges and mounting feet cast integral with the lower half casing. Tapped and plugged holes shall be provided for priming, vent drain and gauge connections. Upper half casing shall be removable without disturbing suction or discharge piping. Suction and discharge shall be on a common center line in both the horizontal and vertical planes.

### **Impeller :**

The impeller shall be of the enclosed double suction type (single stage pumps) and enclosed single suction type (two stage pumps), non-overloading in operating characteristics and statically and hydraulically balanced. The impeller shall be keyed to the shaft and positioned axially by the shaft sleeve or impeller nut both at DE and NDE side.

### **Shaft :**

The shaft shall be of properly designed size to operate under load with a shaft deflection below 50 micron under mechanical seal..

### **Shaft Sleeve :**

In case of gland packed pump shaft sleeve is provided both at DE and NDE side of pump to protect the shaft against wear mark.

### **Stuffing Box :**

Separable Stuffing Box which can accommodate either gland packing or mechanical seal. The stuffing box diameter is universal.

### **Casing Rings :**

The casing rings shall be installed with an anti-rotation pin and designed to restrict leakage across the impeller wear ring.

### **Bearings :**

Grease lubricated Ball bearings both at DE and NDE.

### **Bearing Housing :**

The bearing housings shall be bolted to casing upper and lower half.

### **Direction Of Rotation :**

Standard : Clockwise (CW) viewed from driving end..

Optional : Anti-Clockwise (CCW) viewed from driving end.

# PUMP OUTLINE DIMENSION DETAILS :

## SINGLE STAGE PUMP:

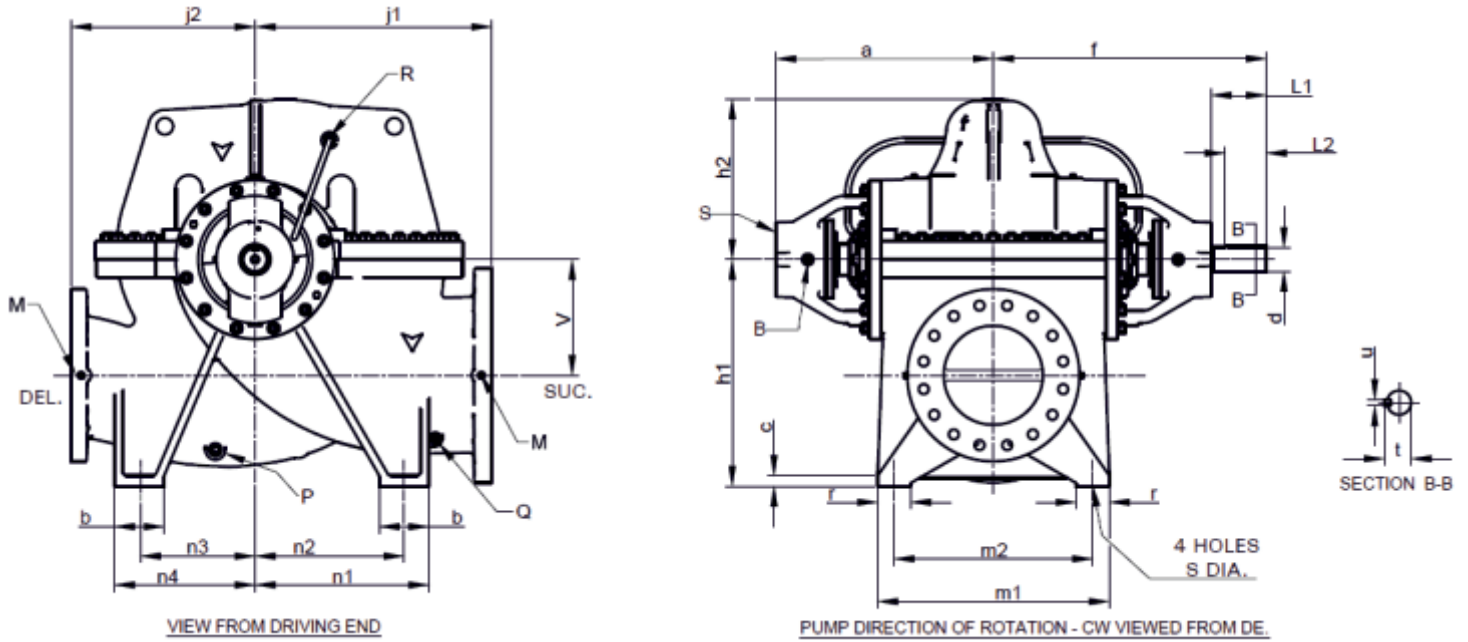

**DIMENSION DETAILS :** (All dimensions are in 'mm 'except specified)

PUMP TYPE : HL200/60E-L																							
SUC	DEL	a	f	h1	h2	j1	j2	v	m1	m2	n1	n2	n3	n4	b	c	r	s	t	u	d	L1	L2
250	200	557.5	735	500	405	580	520	270	460	400	345	250	250	345	145	25	60	24	64	18	60	177.5	125
PUMP TYPE : HL300/63A-L																							
400	300	658	825	685	485	720	560	350	700	600	525	450	350	425	150	32	100	28	79.5	20	75	167	125
PUMP TYPE : HL300/51-L																							
400	300	624	835	675	435	600	525	350	570	500	385	300	300	385	145	32	80	28	63.9	18	60	211	125
PUMP TYPE : HL250/47E-L																							
300	250	606	819	550	395	600	520	280	450	400	315	250	250	315	115	25	60	22	64	18	60	223	125

**FLANGE DRILLING DETAILS :**(All dimensions are in 'mm 'except specified)

Pump Type	Nozzle	Flange Drilling Rating	Diameter	Outer Diameter	PCD	Raise Face Diameter	Raise Face Thickness	Drill Size	No Of Holes
HL200/60EL	Suction	ANSI 125	250	445	362	NA	NA	25	12
	Delivery		200	381	298.5	NA	NA	22	8
HL300/63AL	Suction	BSEN PN25	400	648	550	503	4	36	16
	Delivery		300	521	430	389	4	30	16
HL300/51C/D-L	Suction	ANSI 125	400	650	540	NA	NA	28	16
	Delivery		300	520	432	NA	NA	25	12
HL250/47E-L	Suction	BSEN PN16	300	485	410	NA	NA	26	12
	Delivery		250	425	355	NA	NA	26	12

# PUMP OUTLINE DIMENSION DETAILS :

## TWO STAGE PUMP:

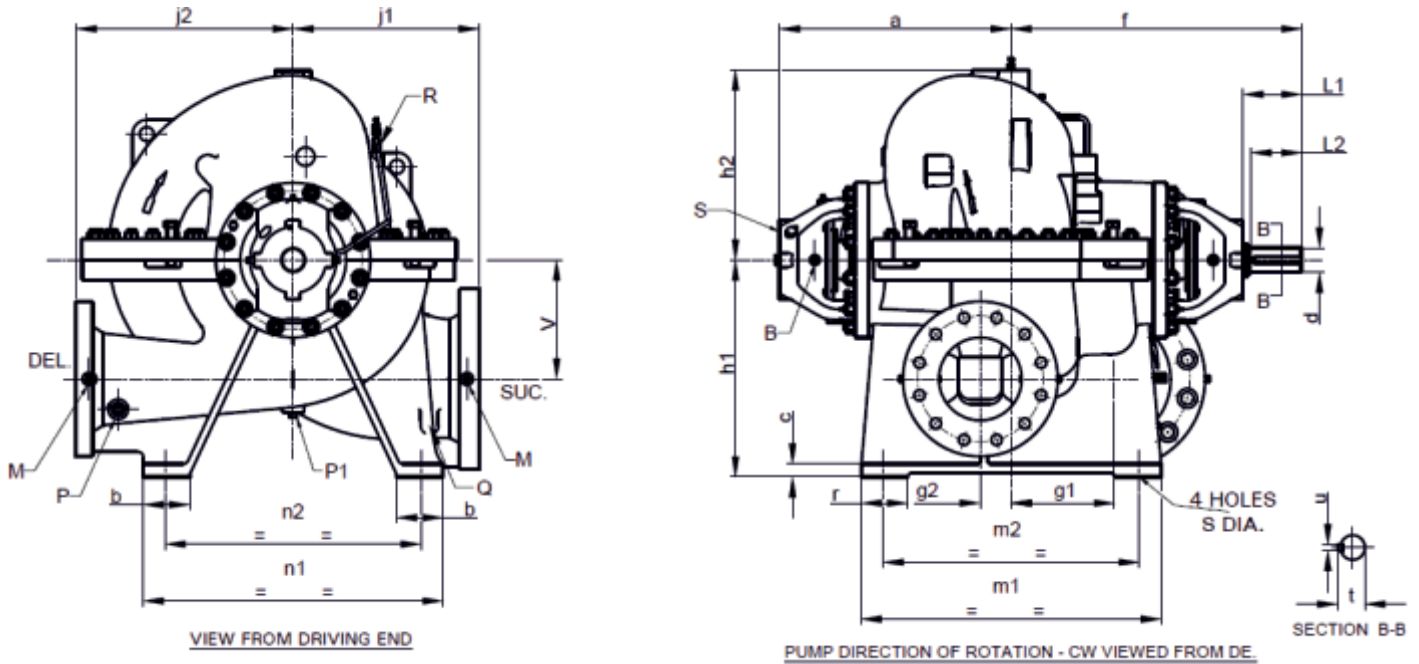

## DIMENSION DETAILS : (All dimensions are in 'mm 'except specified)

PUMP TYPE : HL200/48-2D-L																						
SUC	DEL	a	f	g1	g2	h1	h2	j1	j2	v	m1	m2	n1	n2	b	c	r	s	t	u	d	L1/L2
250	200	569.5	714.5	254.5	76.2	533	467	457	533	292	737	660	737	660	114	32	114	28	64	18	60	145/125
PUMP TYPE : HL125/40-2																						
SUC	DEL	a	f	g1	g2	h1	h2	j1	j2	v	m1	m2	n1	n2	b	c	r	s	t	u	d	L1/L2
150	125	417	535	152.4	44.5	381	372	355.6	406	229	483	406	559	482.6	89	25	89	24	48.5	14	45	120/100

## FLANGE DRILLING DETAILS : (All dimensions are in 'mm 'except specified)

Pump Type	Nozzle	Flange Drilling Rating	Diameter	Outer Diameter	PCD	Raise Face Diameter	Raise Face Thickness	Drill Size	No Of Holes
HL200/48-2	Suction	ANSI 250	250	445	370	NA	NA	30	12
	Delivery		200	381	310	NA	NA	26	12
HL125/40-2	Suction	ANSI 250	150	320	269.75	NA	NA	22.35	8
	Delivery		125	280	234.95	NA	NA	22.35	8
	Suction	BSEN PN25	150	320	250	NA	NA	28	8
	Delivery		125	280	220	NA	NA	28	8

# PUMP OUTLINE DIMENSION DETAILS :

## TWO STAGE PUMP:

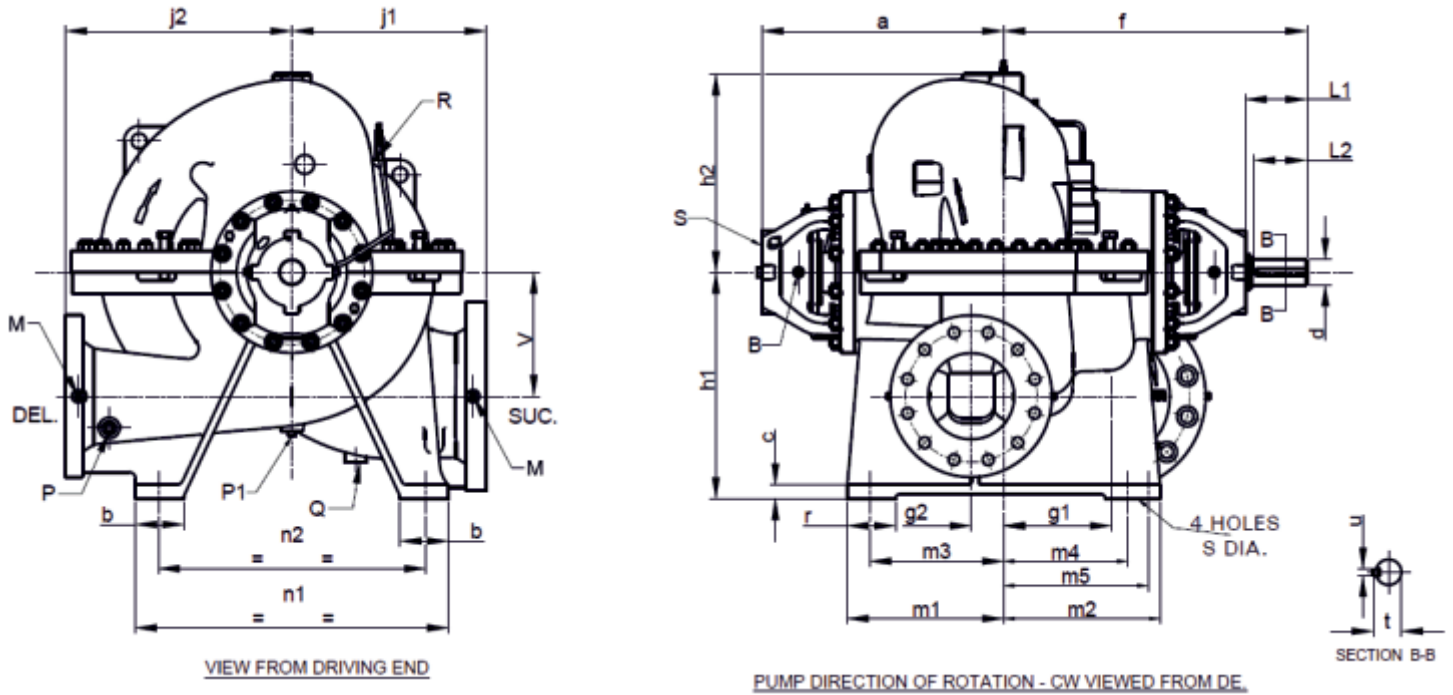

### DIMENSION DETAILS : (All dimensions are in 'mm 'except specified)

PUMP TYPE : HL150/45-2																					
SUC	DEL	a	f	g1	g2	h1	h2	j1	j2	v	m1	m2	m3	m4	m5	n1	n2	b	c	r	s
200	150	459.5	570	165	50.8	432	416	406.4	457	267	254	340	215.6	215.6	300.6	635	559	102	29	102	25

s	t	u	d	L1	L2
25	48.5	14	45	110.5	98

### FLANGE DRILLING DETAILS :(All dimensions are in 'mm 'except specified)

Pump Type	Nozzle	Flange Drilling Rating	Diameter	Outer Diameter	PCD	Raise Face Diameter	Raise Face Thickness	Drill Size	No Of Holes
HL150/45-2 (BM06JL(T))	Suction	ANSI 250	200	380	330	NA	NA	25.4	12
	Delivery		150	320	270	NA	NA	22.4	12
	Suction	BSEN PN25	200	380	310	NA	NA	28	12
	Delivery		150	320	250	NA	NA	28	8

## CONNECTION DETAILS AND WEIGHT :

### CONNECTION DETAILS :

Connection Description	HL200/60E-L	HL300/63A-L	HL300/51-L	HL250/47E-L
Pressure gauge connection 'M'	½"BSP	½"BSP	½"BSP	½"BSP
Casing drain delivery 'P'	1 ½"BSP	½"BSP	½"BSP	1"BSP
Casing drain suction 'Q'	½"BSP	½"BSP	½"BSP	½"BSP
Sealing connection 'R'	½"BSP	½"BSP	½"BSP	½"BSP
Vibration sensor connection 'S'	M8X1.25 TAP			
Btd/rtd connection 'B'	½"BSP			

Connection description	HL200/48-2	HL125/40-2
Pressure gauge connection 'M'	3/8"BSP	¼"BSP
Casing drain suction 'Q'	3/8"BSP	½"BSP
Casing drain delivery 'P'	1"BSP	NA
Casing drain (bottom) 'P1'	1"BSP	¼"BSP
Sealing connection 'R'	¼"BSP	¼"BSP
Vibration sensor connection 'S'	M8X1.25 TAP	
Btd/rtd connection 'B'	½"BSP	

Connection description	HL150/45-2
Pressure gauge connection 'M'	3/8"BSP
Casing drain suction 'Q'	3/8"BSP
Casing drain delivery 'P'	1"BSP
Casing drain (bottom) 'P1'	3/8"BSP
Sealing connection 'R'	¼"BSP
Vibration sensor connection 'S'	M8X1.25 TAP
Btd/rtd connection 'B'	½"BSP

### BARE SHAFT PUMP WEIGHT (Approx.) :

PUMP TYPE	HL200/60E-L	HL300/63A-L	HL300/51-L	HL250/47E-L	HL200/48-2	HL125/40-2	HL150/45-2
WEIGHT, kg	950	1930	1500	938	1124	442	660

# FAMILY CURVES :

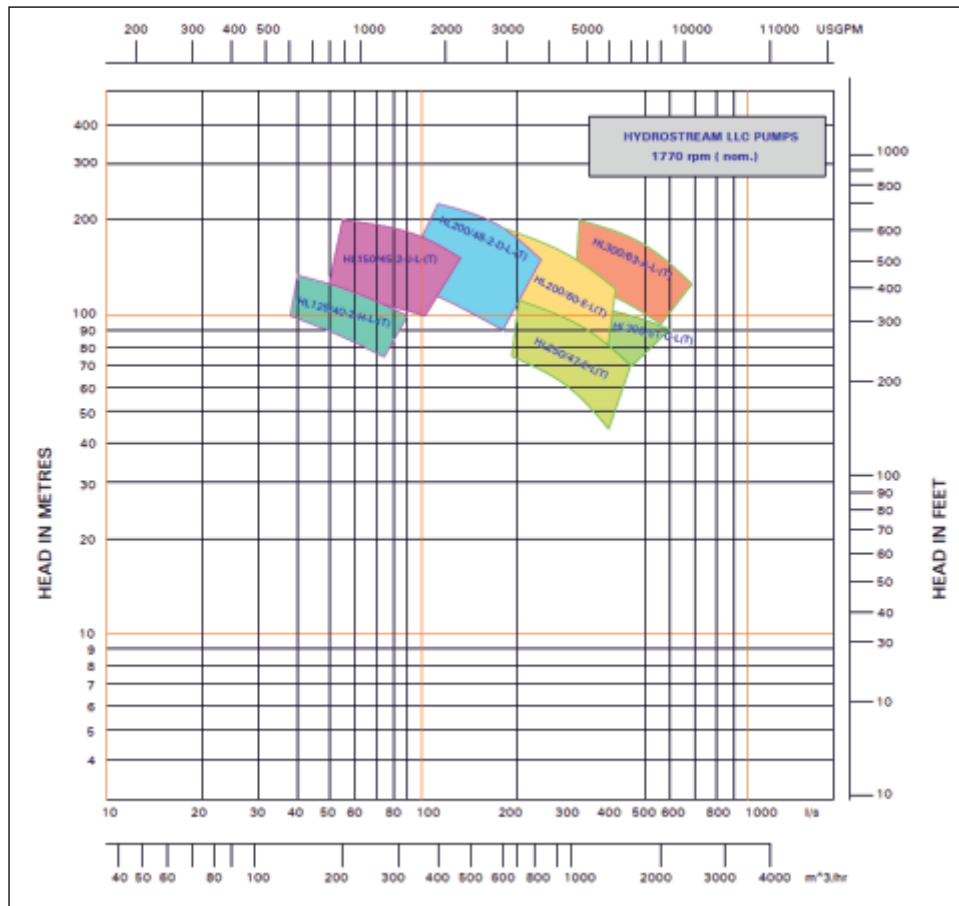
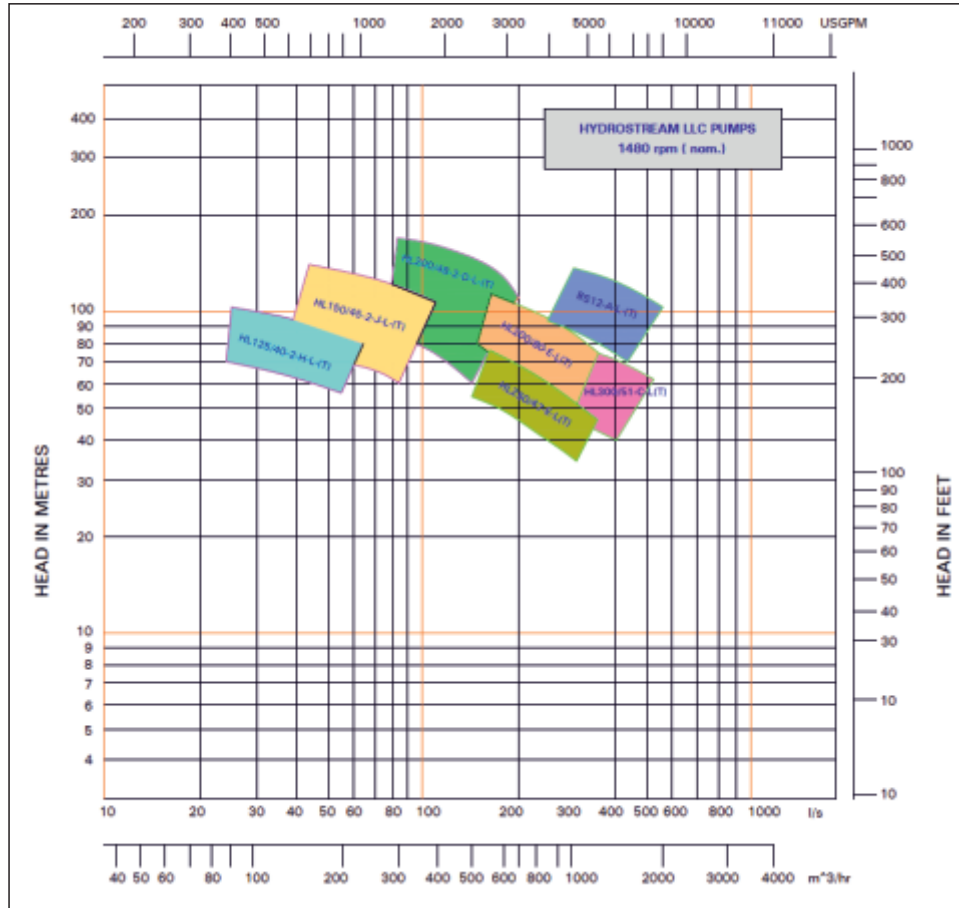

## CROSS SECTIONAL DRAWING (SINGLE STAGE)

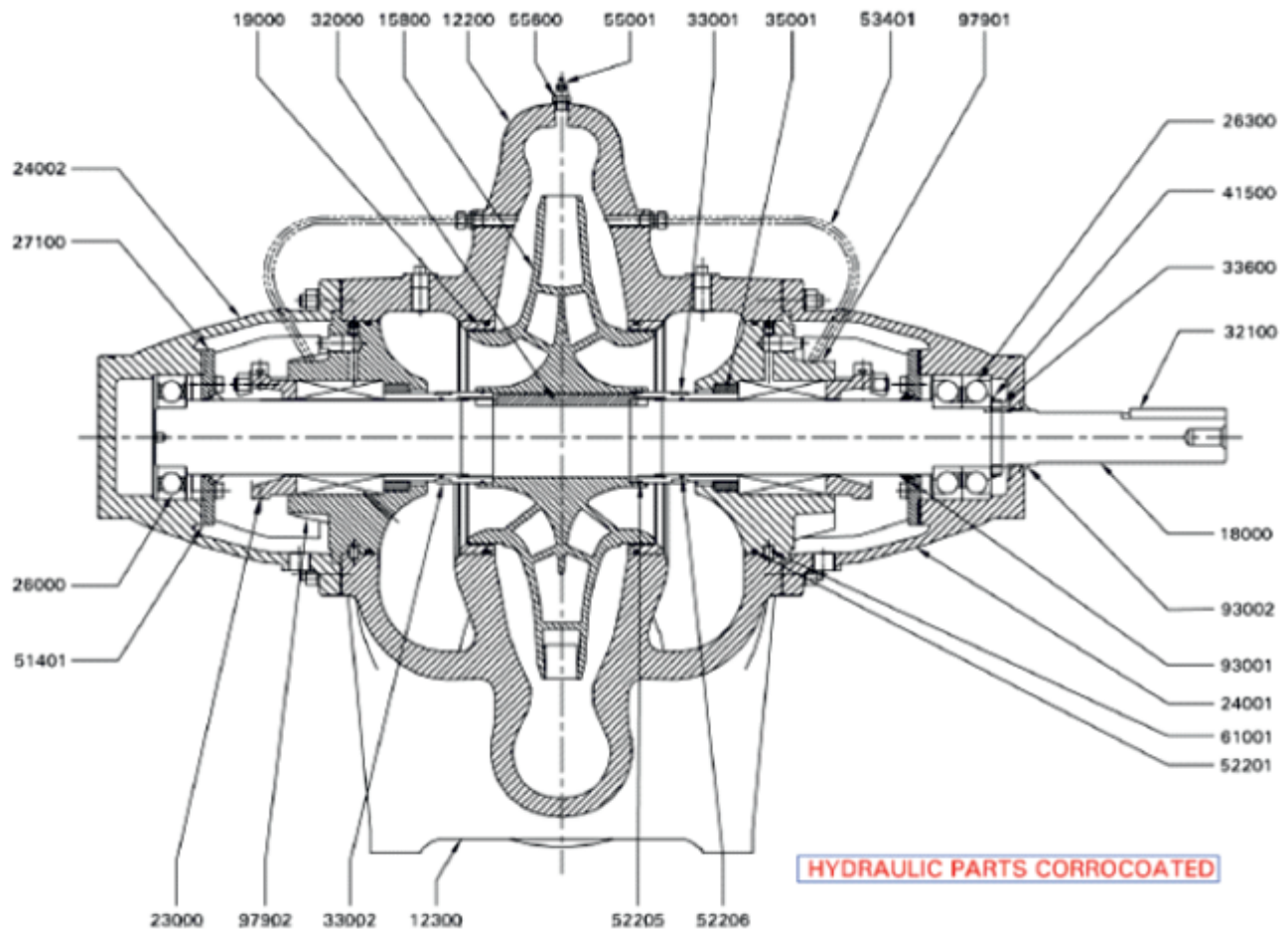

PART NO.	PART DESCRIPTION	MAT. CODE	MOC DESCRIPTION	QTY
12200	CASING HALF UPPER	717	CI FG 260+CORROCOAT+FLUEGLIDE-E	1
12300	CASING HALF LOWER	717	CI FG 260+CORROCOAT+FLUEGLIDE-E	1
15800*	IMPELLER	800	ASTMA351-CF8M-ELECTROPOLYSHING	1
18000*	SHAFT	265	SS BSEN 10088-3 X17CrNi16-2(1.4057)QT800	1
19000*	WEAR RING	124	BR BSEN:1982-CC480K(BS1400-CT1)	2
23000*	MECH SEAL	998	CARTRIDGE TYPE	2
24001	BEARING HOUSING DE	012	CI IS210:FG260	1
24002	BEARING HOUSING NDE	012	CI IS210:FG260	1
26000	DEEP GROOVE BALL BEARING	000	STEEL	1
26300	ANG.CONTACT BALL BEARING	000	STEEL	2
27100	BEARING COVER DE & NDE (M/C)	012	CI IS210:FG260	2
32000	KEY-FOR IMPELLER	265	SS BSEN 10088-3 X17CrNi16-2	1
32100	KEY-FOR COUPLING	053	CS IS1570-40C8 HOT RLD	1
33001*	IMPELLER NUT LOCKING	251	ST ST ASTMA 276-316 ANLD	1
33002*	IMPELLER NUT FREE	251	ST ST ASTMA 276-316 ANLD	1
33600	BEARING LOCK NUT	052	CS IS1570-20C8 HOT RLD	1
35001*	THROTTLE BUSH	718	ORKOT SELF LUB. POLYMER BRG - GR. TLMM	2
41500*	LOCK WASHER	050	CS IS1570-10C4 HOT RLD	1
51401	GASKET BEARING CAP	327	JOINTING RUB BONDED CORK SHEET-WRAS	2
51900	GASKET BET T/B CASING	380	NITRILE BONDED CELLULOSE FIBRE	1
52201	O RING: INSERT	371	NEOPRENE RUBBER ASTM D2000 TYPE BE	5
52205	O RING: SLEEVE WITH IMPELLER	371	NEOPRENE RUBBER ASTM D2000 TYPE BE	2
52206	O RING: SLEEVE WITH SHAFT	371	NEOPRENE RUBBER ASTM D2000 TYPE BE	2
53401	FLEXIBLE PIPE	000	IS 1570 Gr. X04Cr.17 Ni12Mo2/HT Steel	2
55001	VENT VALVE	251	ST ST ASTMA276-316 ANLD	1
55800	ADAPTOR NUT	251	ST ST ASTMA276-316 ANLD	2
61001	LOCKING PIN FOR INSERT	251	ST ST ASTMA276-316 ANLD	2
93001	V-RING	371	NEOPRENE RUBBER ASTM D2000 TYPE BE	2
93002	V-RING	371	NEOPRENE RUBBER ASTM D2000 TYPE BE	1
97901	INSERT DE (M/C)	717	CI FG 260+CORROCOAT+FLUEGLIDE-E	1
97902	INSERT NDE (M/C)	717	CI FG 260+CORROCOAT+FLUEGLIDE-E	1

# CROSS SECTIONAL DRAWING (SINGLE STAGE)

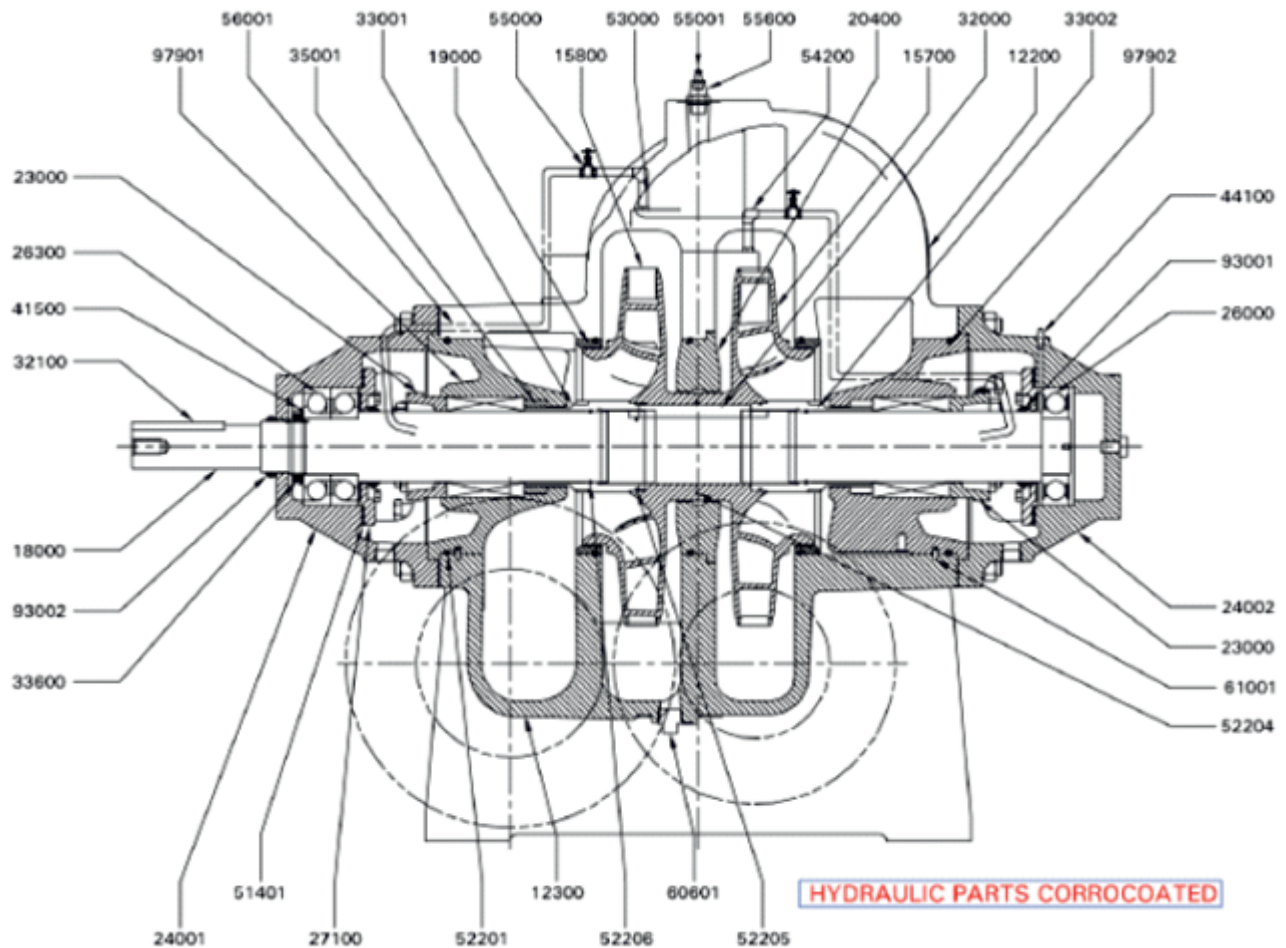

PART NO.	PART DESCRIPTION	MAT. CODE	MOC DESCRIPTION	QTY
12200	CASING HALF UPPER	717	CI FG 280+CORROCOAT+FLUEGLIDE-E	1
12300	CASING HALF LOWER	717	CI FG 280+CORROCOAT+FLUEGLIDE-E	1
15700*	IMPELLER SECOND STAGE	800	ASTMA351-CF8M-ELECTROPOLYSHING	1
15800*	IMPELLER FIRST STGAE	800	ASTMA351-CF8M-ELECTROPOLYSHING	1
18000*	SHAFT	265	SS BSEN 10088-3 X17CrNi16-2(1.4057)QT800	1
19000*	WEAR RING	124	BR BSEN:1982-CC480K(BS1400-CT1)	2
20400*	INTERSTAGE RING	124	BR BSEN:1982-CC480K	1
23000*	MECH SEAL	998	CARTRIDGE TYPE	2
24001	BEARING HOUSING DE	012	CI IS210:FG280	1
24002	BEARING HOUSING NDE	012	CI IS210:FG280	1
26000	DEEP GROOVE BALL BEARING	000	STEEL	1
26300	ANG CONTACT BALL BEARING	000	STEEL	2
27100	BEARING COVER DE & NDE (M/C)	012	CI IS210:FG280	2
32000	KEY-FOR IMPELLER	265	SS BSEN 10088-3 X17CrNi16-2	1
32100	KEY-FOR COUPLING	053	CS IS1570-40C8 HOT RLD	1
33001*	IMPELLER NUT LOCKING	251	ST ST ASTMA 276-316 ANLD	1
33002*	IMPELLER NUT FREE	251	ST ST ASTMA 276-316 ANLD	1
33600	BEARING LOCK NUT	052	CS IS1570-20C8 HOT RLD	1
35001*	THROTTLE BUSH	718	ORKOT SELF LUB. POLYMER BRG - GR. TLMM	2
41500*	LOCK WASHER	050	CS IS1570-10C4 HOT RLD	1
44100	GREASE NIPPLE	444	IS 1367 PART 3 CL-4.8 CDP	2
51401	GASKET BEARING CAP	327	JOINTING RUB BONDED CORK SHEET-WRAS	2
51900	GASKET BET T/B CASING	380	NITRILE BONDED CELLULOSE FIBRE	1
52201	O RING: INSERT	371	NEOPRENE RUBBER ASTM D2000 TYPE BE	5
52204	O RING: IMPELLER	371	NEOPRENE RUBBER ASTM D2000 TYPE BE	1
52205	O RING: SLEEVE WITH IMPELLER	371	NEOPRENE RUBBER ASTM D2000 TYPE BE	2
52206	O RING: SLEEVE WITH SHAFT	371	NEOPRENE RUBBER ASTM D2000 TYPE BE	2
53000	PIPE NIPPLE	000	ST ST ASTM A289 TUBE/PIPE SEAMLESS-TP316	2
54200	ELBOW	251	ST ST ASTMA276-316 ANLD	1
55000	WHEEL COCK	251	ST ST ASTMA276-316 ANLD	2
55001	VENT VALVE	251	ST ST ASTMA276-316 ANLD	1
55600	ADAPTOR NUT	251	ST ST ASTMA276-316 ANLD	2
56001	FLEX HOSE PIPE	845	IS 1570 Gr. X04Cr.17 Ni12Mo2/HT Steel	2
60601	PIPE PLUG	251	ST ST ASTMA276-316 ANLD	2
61001	LOCKING PIN FOR INSERT	251	ST ST ASTMA276-316 ANLD	2
93001	V-RING	371	NEOPRENE RUBBER ASTM D2000 TYPE BE	2
93002	V-RING	371	NEOPRENE RUBBER ASTM D2000 TYPE BE	1
97901	INSERT DE (M/C)	717	CI FG 280+CORROCOAT+FLUEGLIDE-E	1
97902	INSERT NDE (M/C)	717	CI FG 280+CORROCOAT+FLUEGLIDE-E	1



# ABOUT KBL

Kirloskar Brothers Limited (KBL) is a world class pump manufacturing company with expertise in engineering and manufacture of systems for fluid management. Established in 1888 and incorporated in 1920, KBL is the flagship company of the \$ 2.1 billion Kirloskar Group. KBL, a market leader, provides complete fluid management solutions for large infrastructure projects in the areas of water supply, power plants, irrigation, oil & gas and marine & defence. We engineer and manufacture industrial, agriculture and domestic pumps, valves and hydro turbines.

In 2003, KBL acquired SPP Pumps, United Kingdom and established SPP INC, Atlanta, USA, as a wholly owned subsidiary of SPP, UK to expand its international presence. In 2007, Kirloskar Brothers International B.V., The Netherlands and Kirloskar Brothers (Thailand) Ltd., a wholly owned subsidiary in Thailand, were incorporated. In 2008, KBL incorporated Kirloskar Brothers Europe B.V. (Kirloskar Pompen B.V. since June 2014), a joint venture between Kirloskar International B.V. and Industrial Pump Group, The Netherlands. In 2010, KBL further consolidated its global position by acquiring Braybar Pumps, South Africa. SPP MENA was established in Egypt in 2012. In 2014, KBL acquired SyncroFlo Inc., the largest independent fabricator of commercial and municipal domestic water booster pumps.

To further strengthen its global position, in 2015, Kirloskar Pompen B.V. acquired Rodelta Pumps International, The Netherlands.

KBL has joint venture cooperation with Ebara, Japan since 1988 for the manufacture of API 610 standard pumps. Kirloskar Corrocoat Private Limited is a joint venture cooperation with Corrocoat, UK since 2006. KBL acquired The Kolhapur Steel Limited in 2007 and Hematic Motors in 2010.

KBL has eight manufacturing facilities in India at Kirloskarvadi, Dewas, Kondhapuri, Shirwal, Sanand, Kaniyur, Kolhapur and Karad. In addition, KBL has global manufacturing and packaging facilities in Egypt, South Africa, Thailand, The Netherlands, United Arab Emirates, United Kingdom and United States of America. KBL has 12,700 channel partners in India and 80 overseas and is supported by best-in-class network of Authorised Centres and Authorised Refurbishment Centres across the country.

All the manufacturing facilities at KBL are certified for ISO 9001, ISO 14001, ISO 50001, BS OHSAS 18001 and SA8000. In addition, the Kirloskarvadi plant is also certified for N & NPT Stamp. KBL's corporate office in Pune is certified for ISO 9001 & Sa8000.

The factories deploy Total Quality Management tools using European Foundation for Quality Management (EFQM) model. The Kirloskarvadi plant of KBL is a state-of-the-art integrated manufacturing facility having Asia's largest hydraulic research centre with testing facility upto 5000 kW and 50,000 m<sup>3</sup>/hr.

KBL is the ninth pump manufacturing company in the world to be accredited with the N and NPT certification by American Society of Mechanical Engineers (ASME).

---

Pumps | Valves | Hydro Turbines | Turnkey Projects

Water Resource Management | Irrigation | Power | Industry | Oil & Gas | Marine & Defence | Building & Construction | Distribution (Small Pumps) | Valves | Customer Service & Spares

---

## KIRLOSKAR BROTHERS LIMITED

Established 1888

A Kirloskar Group Company

Registered Office & Global Headquarters : "Yamuna", S.No. 98(3-7), Plot No. 3,  
Baner, Pune 411045. Maharashtra, India. Phone: +91(20)27214444 | Email: marketing@kbl.co.in  
Website: www.kirloskarpumps.com | CIN No.: L29113PN1920PLC000670

### OUR COMPANIES



United Kingdom



U.S.A.



South Africa



India



The Netherlands