



Enriching Lives

**INSTRUCTIONS
ON INSTALLATION,
OPERATION AND
MAINTENANCE FOR
KIRLOSKAR
MULTI DOOR
NON RETURN
VALVE**



KIRLOSKAR BROTHERS LIMITED

Established 1888

A Kirloskar Group Company

INDEX

- 1. Introduction**
- 2. Inspections on Receipt, Handling, Storage & Preservation**
 - 2.1 Inspection on Receipt & Handling**
 - 2.2 Storage & prevention**
- 3. Instructions for Installation**
 - 3.1 Checks on Valve Assembly before Installation**
 - 3.2 Checks for the Pipeline before Installation**
- 4. Commissioning**
 - 4.1 Pre- commissioning Checks**
 - 4.2 Commissioning**
- 5. Operation**
- 6. Maintenance Instructions**
- 7. Troubleshooting of Kirloskar Multi Door Non Return Valves**
- 8. Recommended Spares**
- 9. Warranty Clause**
- 10. Safety Instructions**
- 11. Environmental Aspect**
- 12. Product Recycle Program**
- 13. Ordering Information**
- 14. Intimating product / performance complaint**

KIRLOSKAR MULTI DOOR NON RETURN VALVES

1. INTRODUCTION

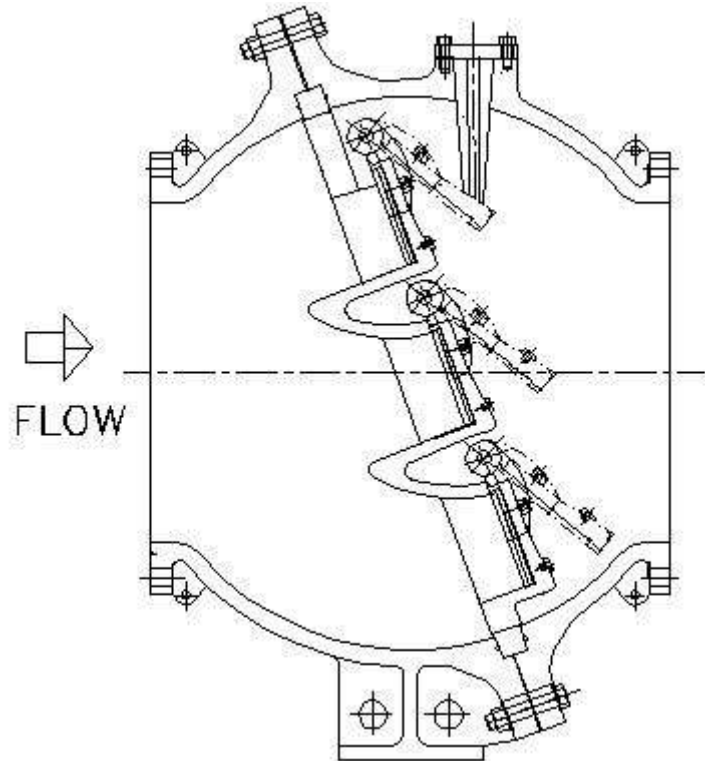

Multi Door Non Return valve
Typical View

Figure 1

Kirloskar Multi Door Non Return Valves generally conform to IS 5312, Part-2 standard for dimensions, materials of construction and constructional features, as per the need of the application. These Multi Door Non Return Valves are Metal Seated type with a choice of by-pass arrangement as an optional accessory and have proven performance.

The doors of the Multi Door Non Return Valve are hinged on Diaphragm. Door Rings and Diaphragm Rings are precisely machined, scraped and lapped to get mirror finish for achieving leak-tightness.

In Kirloskar Multi Door Non Return Valves, No. of Doors are two for sizes 600 to 800mm, three for sizes 900 & 1000mm and four for sizes 1100 & 1200mm.

By-pass arrangement is provided at specific requirement from customer, and the size of by-pass arrangement is referred from standard IS: 5312, Part-2.

2. INSPECTION ON RECEIPT, HANDLING, STORAGE & PRESERVATION

2.1 INSPECTION ON RECEIPT AND HANDLING

- a. At receipt of the product, ensure that there are no transit damages to the product received, especially on valve flanges, door / diaphragm ring faces etc.
- b. Also ensure that Parts and Accessories are received as per ordered scope of supply.
- c. Ensure that adequate numbers of fasteners for mounting accessories are received.
- d. While unloading the product, please use the provision of lifting made on the valve (e.g. Lifting Lugs, Lifting eye bolts).
- e. Use the safe lifting devices (e.g. slings, hoists, hooks etc.) of adequate capacity.
- f. Do not pass the slings through the weak parts of the product / accessory (e.g. By-pass bends – when it is assembled with the valve).
- g. The valve should be transported so that the Inlet Side flange rests on the horizontal floor.
- h. Support the valve properly during transportation to avoid toppling.
- i. Handle the product carefully – do not push, drag, drop from height. If damages, short supply or wrong supply are observed, report the same immediately to the contact person mentioned in this manual.

2.2 STORAGE & PRESERVATION

If the valve has to be stored at site before installation,

- a. Store it on horizontal level surface in dry and clean atmosphere.
- b. Store the products in well-covered sheds, protected from sun, rain and dust.
- c. In the instance if the valve is required to be stored for long duration, ensure that rust preventive should be applied on the machined corrodible surfaces.
- d. It is advisable to give a coat of grease on seat rings during the storage period. Keep the seat rings away dusty atmosphere.
- e. In the instance if, spares supplied along with valve need to store for long duration, ensure that the shelf life of all elastomers is marked on each spare item. For shelf life of elastomer, refer below table-

Sr. No	Component	Shelf Life
01	Rubber sheets	a) Shelf Life or Expiry date specified on product or b) 08 Months from date of supply.
02	Rubber cords/Gaskets / Seals/ O Rings /U cup seal etc.	a) Shelf Life or Expiry date specified on product or b) 18 Months from date of supply.

Note: All rubber, elastomer components shall be kept in covered area away from sunlight or rain at room temperature. It shall be kept protected from sharp metal corners to avoid any damage.

3. INSTRUCTIONS FOR INSTALLATION

CHECKS ON THE VALVE ASSEMBLY BEFORE INSTALLATION

- a. Before taking the Multi Door Non Return Valve for pipe installation, make sure that it is cleaned from inside and outside and there are no foreign or metallic objects sticking on to its sealing elements. Also clean the valve interior passages to remove any foreign matter & rust preventive on machined surfaces.
- b. Ensure that the entire rust preventive on the machined surface in the flow area is removed, before the valve is put in pipe-line.
- c. Note the name plate details on valve body and check valve pressure rating adequacy with respect to operating pressure. Also check direction of flow in the pipe-line and place the Multi Door Non Return Valve accordingly.
- d. Valves should be installed in the pipeline, only after verifying the sealing ability of valve. This can be done by examination of the seat surfaces for freedom from surface damages, scratch marks / dent marks as well as uniform mating of body diaphragm rings and door rings. If any abnormalities are observed, contact KBL.
- e. Multi Door Non Return Valves are designed to generally operate horizontal pipe lines, unless otherwise prior specified by the customer at the time of placement of order.
- f. Operate the Doors of Multi Door Non Return Valve manually from Full Close to Full Open and Full Open to Full Close. Ensure that there is no undue resistance / friction in the operation.
- g. Before connecting valve & pipeline flanges, ensure that they do not have parallel, angular and radial gaps. While fitting the valve in pipeline, ensure that diagonally opposite bolts are simultaneously & uniformly tightened.
- h. Orientation of Hinge Pins of the valve, while fitting in the pipe-line must be horizontal. This can be ensured by checking level of the support for the valve foot, using spirit level.

3.2 CHECKS FOR THE PIPE-LINE BEFORE INSTALLATION

- a. Clean the pipeline thoroughly so that it does not contain any solid matters which may damage the valve internals.
- b. Avoid parallel, radial and angular mismatch between connecting flanges of valve and the pipeline.
- c. Upstream and downstream piping should be adequately supported and anchored (if required) in such a way that the piping system does not impose any forces & moments on the valve body and the hydraulic thrust arising due to valve closure is carried & sustained by valve supports. Valve flanges are not designed to carry any external loads and moments arising due to pipe expansions / contractions. It is advisable to use Flange Adapter Assembly, after

- the valve to facilitate valve dismantling and to prevent any undue loads being transmitted to valve flange.
- d. Provide suitable concrete block with foundation bolts for supporting the valves. It is advisable to install a support for the valve at bottom to prevent any sagging to be caused by weight of the valve.
 - e. Ensure that pipeline flanges are parallel and are mating the valve flange without leaving any parallel or angular gap between the flanges. Do not over-tighten the flange bolts / nuts to make the flanges parallel forcefully. That may develop undue stresses in the valve flanges & body leading their deformation & malfunctioning.
 - f. If the Multi Door Non Return Valves are supplied with By-pass arrangement (against specific order requirement), ensure the by-pass arrangement on the valve is intact.
 - g. Maximum flow velocity in the pipe-line should not exceed 4 m/s.
 - h. The valves are mainly designed for handling clear water with maximum impurities of 5000 PPM.

4. COMMISSIONING

4.1 PRE-COMMISSIONING CHECKS

- a. Ensure manually that the valve doors open and close smoothly.
- b. Flow Direction of the valve matches with that in the pipeline.
- c. The entire pipe flange bolting is properly tightened.
- d. Surge protection devices (if any) are operative.

4.2 COMMISSIONING

- a. Open the By-pass Valve across the valve (if provided).
- b. Charge the pipe-line with water.
- c. Ensure that there is no leakage through flange gaskets. Now the valve is commissioned for its Operation.

5. OPERATION

- a. By-pass valve (if provided) – keep it open while every Start / Stop operation cycle of the Pump.
- b. Once the Multi Door Non Return Valve is closed, the By-pass valve may be kept closed till next operation of the valve.

6. MAINTENANCE INSTRUCTIONS

Maintenance Check Points:

Sr No.	Parameter to Check	Method of checking	Weekly	During Overhaul
01	Leakage through valve seat	Visual / Feel	*	*
02	Noise / Vibrations while Opening or Closing the Valve	Feel	*	
03	Condition of Door Ring / Diaphragm Ring faces – scratches, dent marks, intactness & continuity of contact	Visual & feeler gauge		*
04	Condition of Hinge Pins	Visual		*

Kirloskar Multi Door Non Return Valves require very little maintenance if maintenance check point are attended to during periodic inspection & during overhaul. However, valves could malfunction in unusual conditions of usage, water contamination and may require maintenance as below:

7. TROUBLE SHOOTING OF KIRLOSKAR MULTI DOOR NON RETURN VALVES

Sr.	Problem	Probable Reason	Action Required
01	Leakage through the valve seat	a. By-pass connection open (if by-pass arrangement is provided)	a. Close By-pass valve
		b. External object caught between door ring & diaphragm ring.	b. Try to flush away the external object by creating flow to flush it away. If it does not work, open flanged joint to reach the object and remove it manually (**).
		c. Worn out / Deformed or damaged seat rings	c. Replace the Door Rings / Diaphragm rings (%%)
02	Leakage through side flanges	a. Inadequate tightening of flanged joint	a. Re-tighten the flanged joint
		b. Damaged gasket	b. Replace gasket (**)
		c. Parallel / angular gap between valve and pipe flanges	Remove parallel / angular gap between valve and pipe flanges (**)
03	Noise/vibrations during operation & during closure	Inadequately supported /	Support / fix upstream / downstream piping & valve (with foundation bolts where applicable)
		inadequately fixed piping / valve	



IMPORTANT ():** All these procedures require emptying the upstream and downstream piping and removal of the valve from the pipeline.

(%%) : As the Diaphragm Rings / Door Rings require very precise machining for mating surface we strongly recommend that this operation of Diaphragm Ring / Door Ring fitment should be carried out at KBL factory only.

8. Recommended Spares for Multi Door Non Return Valves

Product Cross Sectional and General Assembly Drawing attached with this manual indicates the components of the respective valves, along with the recommended spares.

We strongly recommend to keep the spares handy all the time to be able to eliminate delays in attending the operation troubles and scheduled replacements / overhauls.

9. WARRANTY CLAUSE:

Kirloskar Brothers Limited (KBL) warrants that the valve manufactured and supplied by KBL to be free from defects in material, workmanship and construction, when used in accordance with installation and technical instructions provided, for a period of twelve months from the date of commissioning of the equipment or 18 months from the date of dispatch of valve from its factory, whichever is earlier.

THIS WARRANTY DOES NOT APPLY TO VALVES WHICH ARE MISUSED, OR ABUSED, OR DAMAGED FROM INSTALLATION, OR NOT USED IN ACCORDANCE WITH KBL'S INSTRUCTIONS. NORMAL WEAR OF VALVES IS NOT INCLUDED IN THIS WARRANTY.

Any parts or other accessories not manufactured by Kirloskar Brothers Limited but supplied through KBL shall carry the warranty of the original manufacturer.

KBL'S SOLE LIABILITY UNDER THIS WARRANTY SHALL BE LIMITED TO EITHER REPLACING OR REPAIRING WITHOUT CHARGE, AT ITS FACTORY OR ELSEWHERE AT ITS DISCRETION, ANY VALVE NOT MEETING THIS WARRANTY, OR AT KBL'S OPTION, REFUNDING THE PURCHASE PRICE. KIRLOSKAR BROTHERS LIMITED SHALL IN NO EVENT BE LIABLE FOR ANY OTHER DIRECT OR ANY SPECIAL INDIRECT OR CONSEQUENTIAL DAMAGES OF ANY KIND UNDER THIS CONTRACT OR OTHERWISE.

Kirloskar Brothers Limited warranty does not cover and KBL makes no warranty with respect to any defects, failures, deficiencies, or errors which include but are not limited to: (a) Not timely reported to KBL; or (b) Due to misapplication, modification, disassembly or abnormal conditions or corrosive matters; or (c) Due to operation, either intentional or otherwise, in an improper manner; (d) damage during transit.

In case of delay of delivery due to lack of instructions from a customer or delay in accepting delivery by a customer, the period of 18 months shall be considered from the date of notification from Kirloskar Brothers Limited to customer that the valves are ready for dispatch.

The foregoing warranty constitutes KBL's sole liability.

THERE ARE NO OTHER WARRANTIES, EXPRESSED OR IMPLIED, INCLUDING THE IMPLIED WARRANTIES OF MERCHANTABILITY AND FITNESS FOR A PARTICULAR PURPOSE.

For Installation , Operation & Maintenance Manuals pl. refer following link :
www.kirloskarpumps.com → DOWNLOAD CENTRE → Product IOM Manual → Product Category → Valve

10. SAFETY INSTRUCTIONS

SAFETY INSTRUCTIONS FOR" KIRLOSKAR MAKE VALVE TO BE FOLLOWED BY USER, AT SITE



[These Safety Instructions are the integral part of the IOM Manual]

PART – I: GENERAL INFORMATION & SAFETY REQUIREMENTS

The Products supplied by KBL have been designed with safety in mind. Where hazards can not be eliminated, the risk has been minimized by the use of guards and other design features. Some hazards can not be guarded against and the instructions below **MUST BE COMPLIED WITH** for safe operations. These instructions can not cover all circumstances; USER of the product is responsible for using safe-working practices at all times.

KBL product are designed for installation in designated area, which are to be kept clean and free of obstructions that may restrict safe access to the controls and maintenance access points.

Access to the equipment should be kept restricted to the personnel responsible for installation, operation and maintenance and they must be trained, adequately qualified and supplied with adequate tools for their respective tasks.

KBL requires that, all personnel that are responsible for installation, operation or maintenance of the equipment, have access to study the product instruction manual BEFORE any work is done and they will comply with all local and industry based safety instructions and regulations.

Personnel protection safety equipment must be worn where local rules apply.

Read the instruction manual before installation, operation and maintenance of the equipment.

Note that the limit of product application and permissible use of the product is according to the respective product design & testing standard and product pressure rating. Operation of the equipment beyond these limits will increase risk from hazards and may lead to premature and hazardous failure of the valve / accessories.

Clear and easy access to all controls etc. must be maintained at all times. Hazardous or flammable materials must not be stored near valves unless safe areas or racking and suitable containers have been provided.

IMPROPER INSTALLATION, OPERATION OR MAINTENANCE OF THE KBL PRODUCT COULD RESULT IN INJURY OR DEATH.

PART – II: SAFETY INSTRUCTIONS WHILE HANDLING, STORAGE AND USAGE

For handling / lifting the valves, and other assembly components, use devices of adequate capacities certified by competent authorities. Use lifting provisions e.g. lifting eyebolts, lifting lugs, lifting holes etc. wherever provided on the valves and the components.

Before fitting the valve in pipeline, ensure that Pressure Rating of the valve is suitable for maximum working pressure / surge pressure that may arise in the pipeline.

User shall prevent any unauthorized person to mount, dismantle or remount, operate and repair the valves.

While using the device, ensure that approved technical rules and regulations e.g. trading regulations, regulations

for prevention of accidents, steam boiler regulations, regulations of gas mains under high pressure, regulations

for combustible fluids, local safety regulations etc. are followed.

During using the valve, ensure that approved technical rules & regulations e.g. trading regulations, regulations for prevention of accidents, local safety regulations etc. are followed.

During repairs / maintenance of the valve at site, the user shall take minimum following precautions:

Provide adequate working platform near the valve.

Make pipelines pressure less and harmless i.e. switch off the pumps, empty the pipelines, remove and switch-off all electric connections (of power pack unit).

If work is carried-out in vicinity of the valve, which leads to dusty atmosphere (e.g. concrete work, masonry, painting, sandblasting etc.) the valve / valve components must be covered effectively.

11. ENVIRONMENTAL ASPECT:

Our products are designed and manufactured considering all environmental aspects to minimize impact on the environment. We ensure that the product supplied by us utilizes less energy during their life cycle and it does not emit any hazardous gas or cause any harm to any living being or to the environment. User of this product is recommended to follow the operating instructions and maintain the product in periodic manner, in order to ensure that it always functions with optimum energy efficiency.

12. PRODUCT RECYCLE PROGRAM:

As a commitment towards a greener future, conservation of natural resources and reduction of carbon foot print, Kirloskar Brothers Limited offers to take back/replace its used products once it has reached the end-of-life and ensure that it is recycled/ disposed in an environment friendly manner with the following objective.

To facilitate our customers for recycling / safe disposal of 'end-of-life' product in environment friendly through a recycle program.

To minimize the impact caused by product disposal on society / environment.

To reuse the recyclable components as secondary source of raw material.

To ensure implementation of control mechanism over third part for recycle/safe disposal of the waste generated.

To offer or replace customer's existing product with more efficient and environment friendly product.

End of life of Kirloskar Brothers Limited product shall be considered, when a customer has declared that the product has become redundant (the product has become obsolete/unfit for use/non-functional and cannot be refurbished in consultation with Kirloskar Brothers Limited personnel) Or the customer wishes to replace the existing product for a shift in technology/for replacement of product by latest/advanced technology of more energy efficient friendly product.

As the product reaches its End-of-Life, the customer shall communicate the same through the Kirloskar Brothers Limited mail ID, customercare.recycle@kbl.co.in or approach the nearest Customer Support Service/Regional Offices/ Authorized Dealer/Authorized Service Dealers who in turn shall communicate the same to Zonal Customer Support Service representative.

13. ORDERING INFORMATION:

(To be sent to the Contact Person mentioned in this manual)

Details required to be furnished while ordering Spares

a. KBL Order Acceptance Number (O/A No. or Sale Order No.)

b. Product Description Type, Size, Pressure Rating etc.

c. Product Serial No. (This is hard punch marked on Valve Flange)

d. KBL SAP Product Code This code is mentioned in the Invoice through which the product has been dispatched.

- e. KBL Cross Sectional Assembly Drawing No. for the product (if provided)
- f. Required Part Name & Part No. as shown in the Cross Sectional Assembly drawing.
- g. Material of construction of the required part, as that appears in the Cross Sectional Assembly drawing.

14. INTIMATING PRODUCT / PERFORMANCE COMPLAINT

(Information to be sent to the Contact Person mentioned in this manual)

While communicating product complaint, furnish following information to help us to resolve the problem promptly.

- h. KBL Order Acceptance Number (O/A No. or Sale Order No.)
- i. Product Description – Type, Size, Pressure Rating etc.
- j. Product Serial No. (This is hard punch marked on Valve Flange)
- k. KBL SAP Product Code – This code is mentioned in the Invoice though which the product has been dispatched.
- l. KBL Cross Sectional Assembly Drawing No. for the product (if provided)
- m. Exact nature of complaint

If the complaint is related to Short Supply, Wrong Supply, Transit Damage, it is necessary to communicate the Invoice Number which will help in tracking the cause of the problem.

In case if you need additional information or help, please contact:

Customer Support Cell

Kirloskar Brothers Limited
“Yamuna”, Survey No.98/ 3 to 7,
Baner,
Pune- 411045
Toll free no: 1800-10-34443
e-mail: kirloskarvalves@kbl.co.in



Enriching Lives

KIRLOSKAR BROTHERS LIMITED

A Kirloskar Group Company

Established 1888

REGISTERED OFFICE : Udyog Bhavan, Tilak Road, Pune – 411002, India. Phone: +91-20-24440770
GLOBAL HEADQUARTERS : "Yamuna", S. No. 98(3 to 7), Baner, Pune – 411045, India. Phone: +91-20-27214444
Email: marketing@kbl.co.in, **Website:** www.kirloskarpumps.com **CIN No.:** L29113PN1920PLC000670

OUR COMPANIES



United Kingdom



U.S.A.



South Africa



India



The Netherlands