

KIRLOSKAR SUBMERSIBLE WASTE WATER PUMP



Enriching Lives

TYPE - iNSx

Where innovation meets eXemplary eXcellence

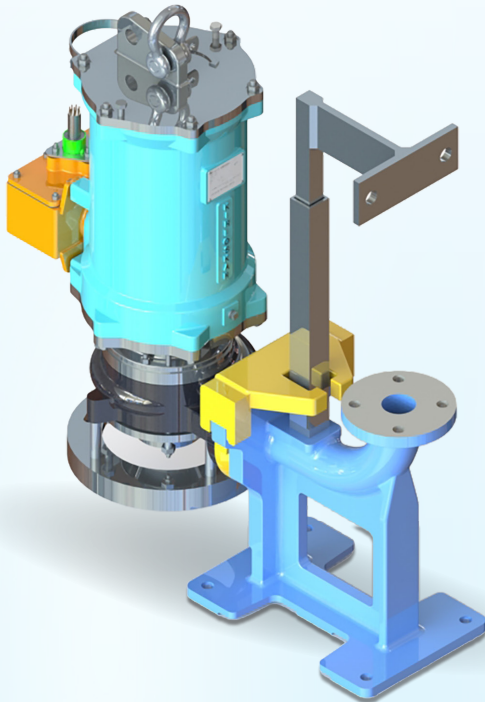

Operating Range

- Delivery sizes: 20 mm to 150 mm
- Flow (Max.) up to 300 m³/hr
- Head (Max.) up to 50 m
- Motor rating up to 22 kW (with premium efficiency IE3)
- Solid size (Max.) up to 125 mm
- Liquid temperature (Max.): 50 degree Celsius
- Cable: EBXL type
- Supply condition
 - ▶ Supply Voltage: Standard three phase 415 +/- 10% (Optional: 400/380 V +/- 10%)
 - ▶ Frequency: 50 Hz +/- 5%
 - ▶ Speed: 2900, 1450 rpm
 - ▶ Protection and Insulation: IP68, F/H Class (Optional)
- Maximum submergence: 25 meter

Material of Construction

- Casing: CI / 2.5% NICI / SGI
- Impeller: CI / WCB / CF8M / 2.5% NICI / SGI
- Shaft: SS410 / Dup SS

Applications

- **Municipal Sewage & Drainage Systems**
Efficient pumping of raw sewage, storm water, and sludge in lift stations and treatment plants.
- **Industrial Wastewater Management**
Reliable handling of effluents and process water in manufacturing, chemical, and food processing industries.
- **Commercial Infrastructure**
Ideal for hotels, malls, hospitals, and office complexes for managing greywater and sewage discharge.
- **Residential & Housing Societies**
Safe and efficient wastewater disposal from basements, septic tanks, and sump pits.
- **Construction & Flood Control**
Effective dewatering of excavation sites, tunnels, and flood-prone areas.

Cross Sectional Drawing

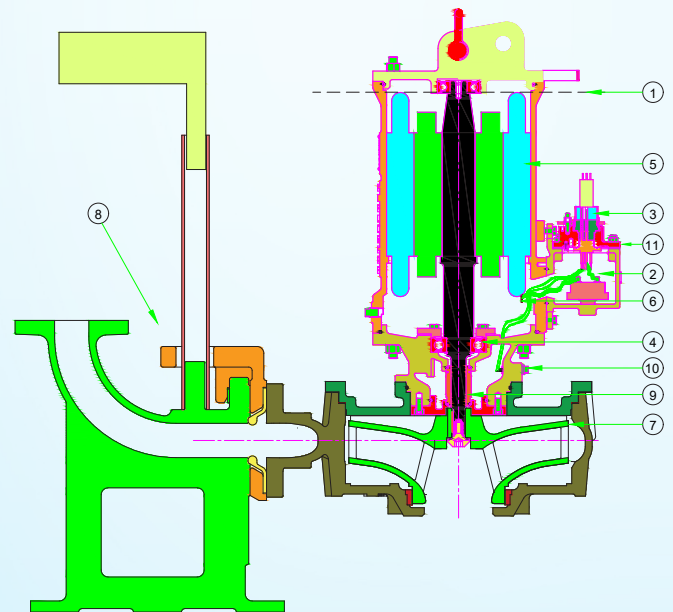

1. Smarter Design- Submergence Slashed
2. Side Terminal Port
3. IP 68 Connector Interface
4. Zero-maintenance bearing
5. Sealed motor with premium efficiency (IE3) with F/H class, S1 duty
6. Intelligent thermal element (Thermistor)
7. Engineered for Peak hydraulic efficiency in waste water application
8. Smart hydraulic docking mechanism
9. Double defense sealing solutions
10. Smart moisture guardian
11. Effortless connection module

KIRLOSKAR BROTHERS LIMITED

Established 1888

A Kirloskar Group Company

Family curves:

4 POLE=

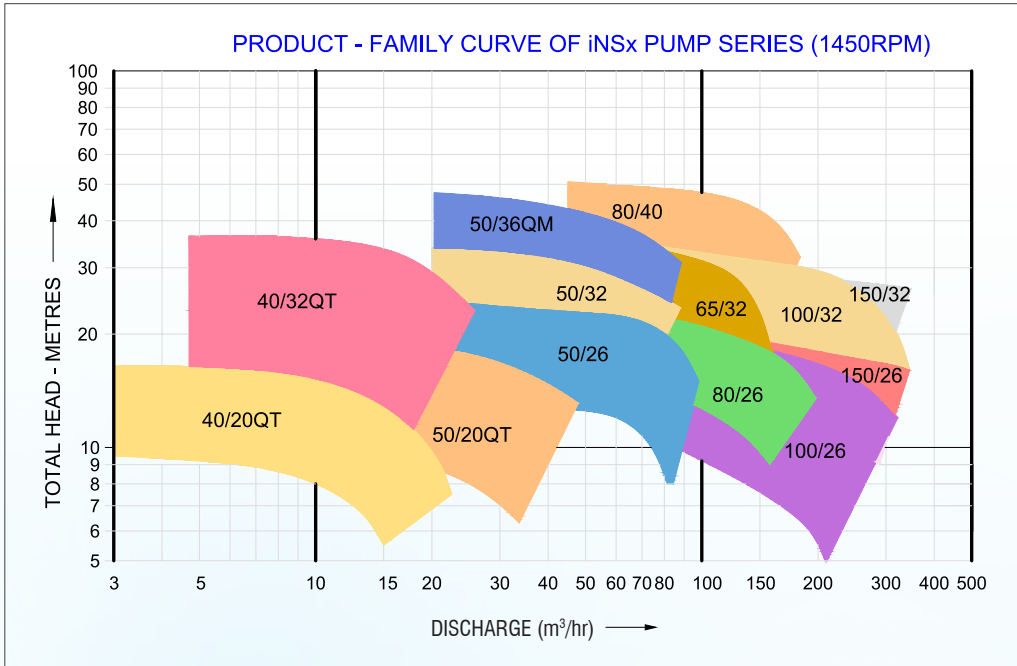

2 POLE=

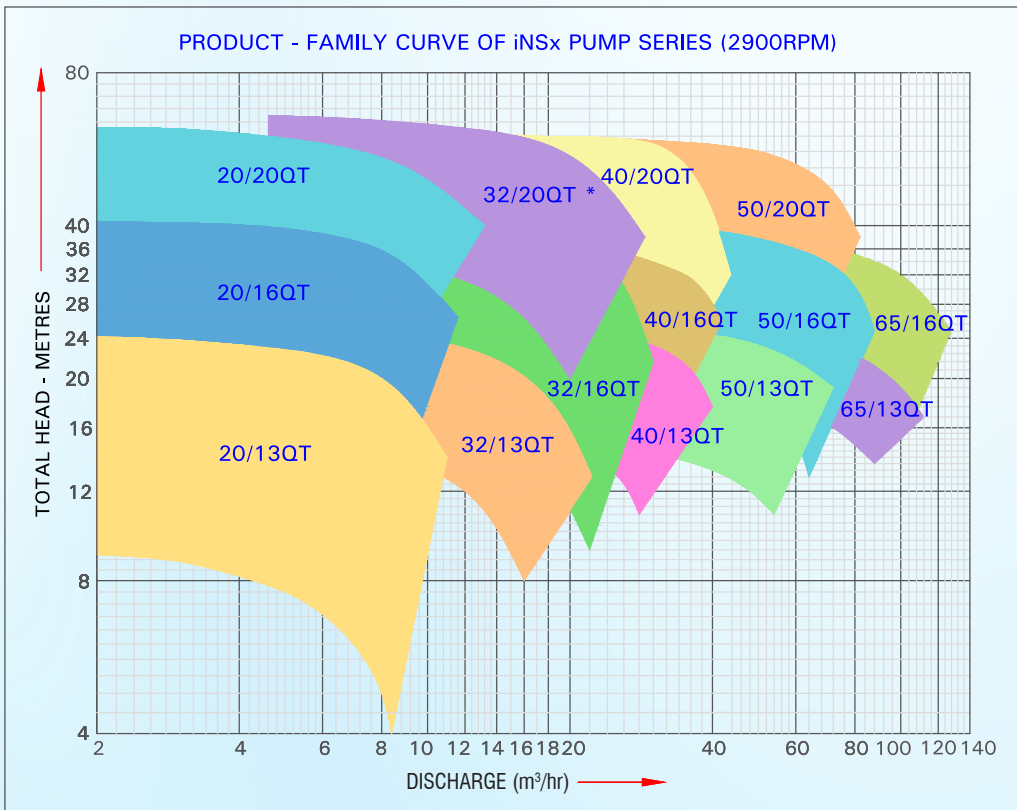

* Not developed.

KIRLOSKAR BROTHERS LIMITED

Established 1888

A Kirloskar Group Company

OUR COMPANIES



BRABBAR PUMPS (PTY) LTD
Republic of South Africa



KARAD PROJECTS AND MOTORS LIMITED
India



KIRLOSKAR BROTHERS (THAILAND) LIMITED
Thailand



KIRLOSKAR CORROCOAT PRIVATE LIMITED
India



KIRLOSKAR EBARA PUMPS LIMITED
India



RODELTA PUMPS INTERNATIONAL B.V.
The Netherlands



SPP PUMPS LIMITED
United Kingdom



SYNCRIFOLO, INC.
U.S.A.

REGISTERED OFFICE & GLOBAL HEADQUARTERS

"Yamuna", S. No. 98/(3-7), Plot No. 3, Baner, Pune - 411 045, Maharashtra, India. | Toll Free: 1800-123-4443 | Phone: +91 (20) 67214444
Email: marketing@kbl.co.in | Fax No. 020 67211060 | Website: www.kirloskarpumps.com | CIN No. L29113PN1920PLC000670

Kirloskar Brothers Limited reserve the right to make alteration from time to time and such our products / equipments may differ from that detail in this publication. For latest information you may get in touch with our Regional Sales Offices.